

2000

Prepared by the Science
Teachers' Association of
Western Australia (Inc).

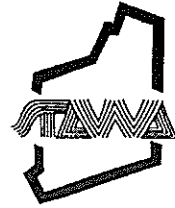

ISSN 0725-6906

Physics

2000 TEE Solutions*



Production, Distribution and Sales:
Science Teachers' Association of
Western Australia (Inc).
PO Box 1099
Osborne Park 6916

**Question papers and solutions
can be obtained from:**
The Curriculum Council
27 Waters Drive
Osborne Park 6017

*These solutions are not a marking key. They are a guide to the possible answers at a depth that might be expected of Year 12 students. It is unlikely that all possible answers to the questions are covered in these solutions.

© 2001 The Science Teachers' Association of Western Australia. STAWA appreciates the support of the Curriculum Council, which provided the marker's guides used a basis for these solutions.

SECTION A

1.

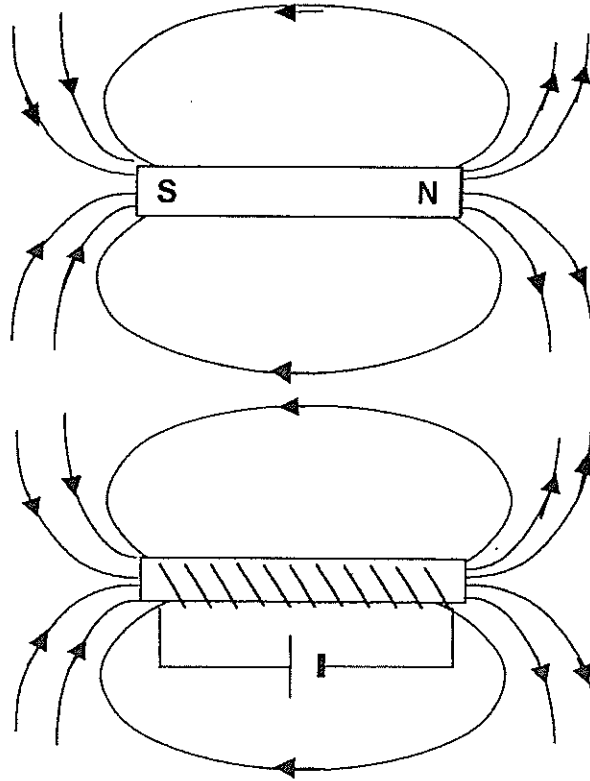

(Note: shapes of fields and arrows showing direction)

2. A Current
 J Energy or work
 T Magnetic flux density or induction
 Wb Magnetic flux

3. Field estimate between 50 – 200 m long, say 150 m.
 Time taken = $s/v = 150/346 = 0.43$ s i.e. approximately **0.5 s**

4.

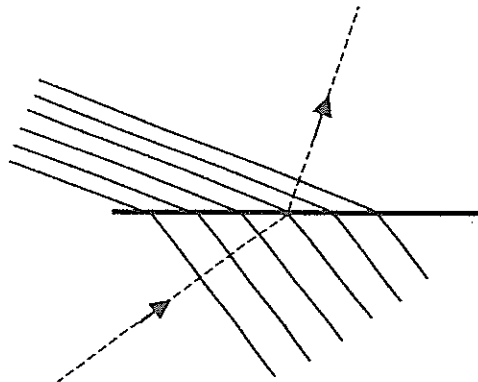

Important points:
 Parallel wave fronts
 Change in wavelength shown
 Wave refracted
 Refraction toward the normal

5. $75 \text{ dB} = 10 \log (I/I_0)$ ($I_0 = 10^{-12} \text{ Wm}^{-2}$)
 $I = 10^{7.5} \times 10^{-12} = 10^{-4.5}$
 $I = 3.16 \times 10^{-5} \text{ Wm}^{-2}$ for each supporter
 For 12 supporters intensity, $I_2 = 12 \times 3.16 \times 10^{-5} = 3.79 \times 10^{-4} \text{ Wm}^{-2}$
 $10 \log I_2 = \mathbf{85.8 \text{ dB}}$
6. The right hand (lower) light is more stable because it has a lower centre of mass and has to be tilted through a larger angle before the centre of mass is no longer above the base.
7. This question requires you to give an example of pulses being fed into a system and the energy being taken up by the system, causing it to vibrate. (Contrast this with "resonance")
 Example: A vibrating tuning fork being touched onto a wooden box, causing the box to vibrate and emit a loud sound.
8. Energy transition = $hf = 6.63 \times 10^{-34} \times 2.65 \times 10^{14} = 1.76 \times 10^{-19} \text{ J}$
 $1.76 \times 10^{-19} / 1.6 \times 10^{-19} = \mathbf{1.10 \text{ eV}}$
 Transition from -12.6 eV to -13.7 eV releases energy = 1.10 eV
 Therefore this is the correct transition \longrightarrow

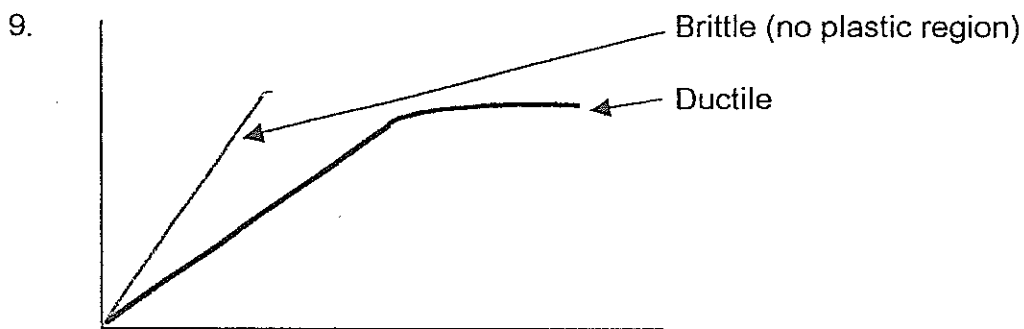
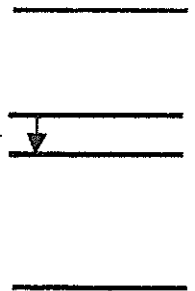

Glass is a **brittle** material

10. For equilibrium:
 Sum of clockwise torques = Sum of anticlockwise torques. ($\tau = F r \sin\theta$)
 The shelf weight gives a clockwise torque around the attachment at the wall and the tension in the strut provides the opposing, balanced torque.

11. Displacement is the maximum distance that a particle of the medium moves from its mean position due to the transmission of the sound wave.

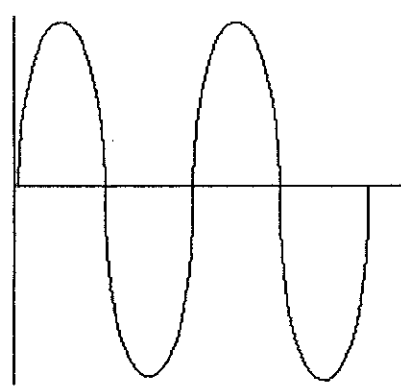

Low pitched sound

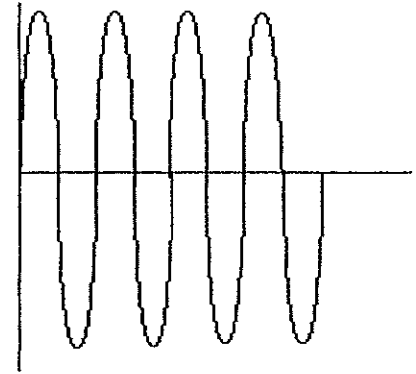

High pitched sound

12. Sound waves DO diffract.

Example

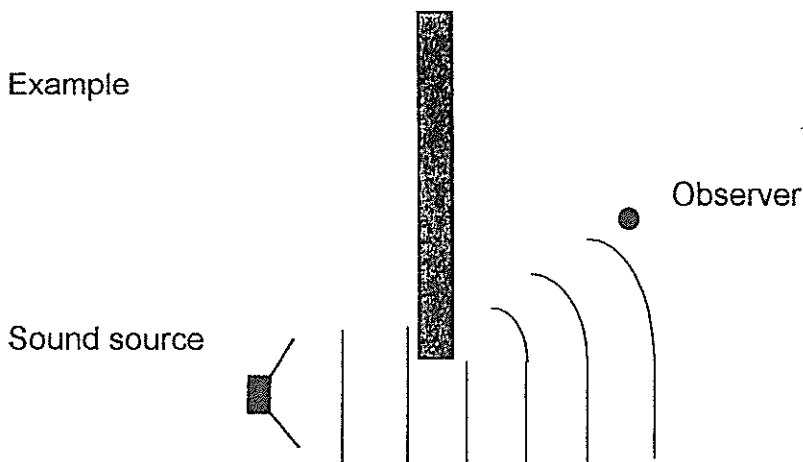

If sound waves did not bend round objects the observer would not be able to hear sound from the source.

This (standard) answer assumes that the barrier is either very reflective or absorbs sound very well and does not transmit sound. In practice an observer in the "shadow" of the sound waves will be able to hear some sound due to transmission of sound through the barrier or due to reflection off other objects in the vicinity.

Some experimentation with a gap of variable width would probably demonstrate diffraction of sound and that diffraction is maximized when the gap is approximately the size of the wavelength of the sound.

13. a) The black box contains a (step-down) transformer.

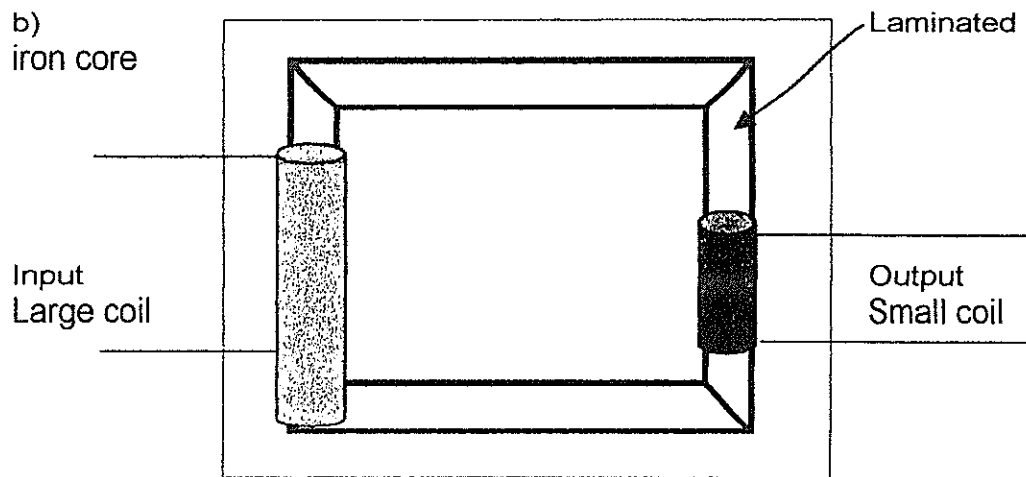

The above diagram is of a standard "demonstration" transformer.

The transformer built into a power lead is configured differently. Efficient commercial transformers are of the "E I" design or the toroidal design.

14. $F = q v B$

$$= (1.6 \times 10^{-19}) \times (1.2 \times 10^7) \times (55 \times 10^{-6})$$

$$= 1.06 \times 10^{-16} \text{ N}$$

15. a.

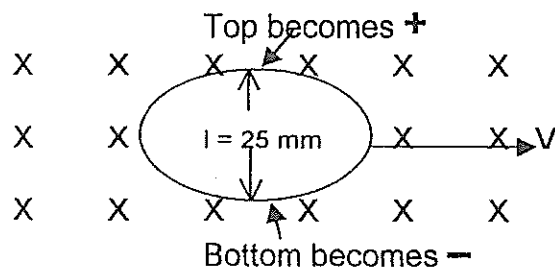

b. $E = l v B$

$$= (25 \times 10^{-3}) \times (30 \times 10^3) \times (30 \times 10^{-6})$$

$$= 2.25 \times 10^{-3} \text{ V}$$

SECTION B

1. a) Fundamental (displacement) 2nd harmonic (displacement)

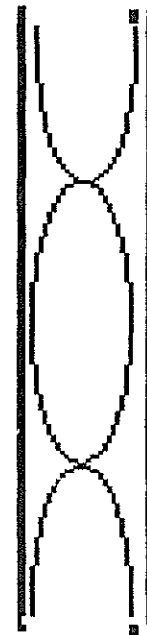
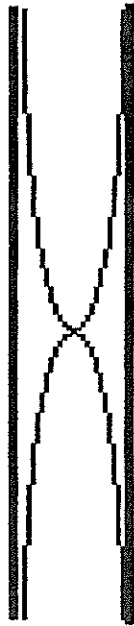

- b) Length of chimney = $\frac{1}{2} \lambda$
 $\lambda = v/f = 346/30 = 11.53\text{m}$
 \therefore Chimney length = **5.8 m**
- c) Tape B would be selected
The note is very low pitched (below human voice frequencies) and would best be recorded onto the special tape effectively.
- d) Yes it matters – the note to be produced is extremely low.
The double bass would be used as it can produce lower notes. It is larger and has longer strings that can vibrate at lower frequencies.

2A.

- a) i) The charged particles collide with atoms in air and cause electrons to move into higher energy levels. When they fall back again they emit photons of a particular frequencies. Different photon energies have different wavelengths.
- ii) Different colours are produced from different electron transitions as the electrons fall. A small energy difference gives low frequency, longer wavelength light.
- b) UV photons have enough energy to ionise molecules in the cell This damages the molecules and can lead to cancer.

IR photons do not have enough energy to cause this ionisation.

- c) Between the Sun and Earth there is a greater thickness of gas to absorb the x-rays. With a bone x-ray there would only be a few metres of air in the room to absorb the rays.

2B

- a) i) Inelastic collision between the electrons accelerated by the high voltage and the atoms of gas in the tube can cause electrons in the gas atoms to move to higher energy levels. When these electrons fall to the ground state they emit the energy as photons.

ii) The difference between the energy levels determines the wavelength of the photons emitted – a large energy jump gives a short wavelength wave.

- b) X-rays photons have enough energy to ionise molecules in cells, including cancerous cells. This can destroy the cancerous growth. IR photons do not have enough energy to ionise molecules in cells.
- c) Higher density materials absorb X-rays better. Bones are dense and absorb better than flesh and so shield the X-ray film from exposure.

2C

- a) i) The phosphor on the screen absorbs energy from fast moving electrons and the electrons of the phosphor become promoted into higher energy levels. When they fall again they emit radiation characteristic of the elements in the phosphor.
- ii) The difference in energy levels determines the colours emitted – the larger the jump, the shorter the wavelength of the emitted photon.
- b) X-rays have very short wavelengths and the photons have enough energy to ionise molecules in cells. This can destroy the cells. IR photons do not have enough energy to ionise molecules in cells.

- c) The sides and top should be made from lead which is a good absorber and only allows rays to travel downwards. This prevents X-rays from irradiating the operator.
The bottom plate would be made from plastic to allow the passage of X-rays downwards towards the sample.

3. a) Current is proportional to induced emf. EMF is greatest when the rate of change of flux is greatest. Flux density is greatest at the end of the magnet, this is the position of the coil where greatest current will be induced. Less flux is "cut" as the coil passes over the magnet. No emf is induced when the coil is stationary.

- b) Moving the coil faster would give a higher and narrower peak since less time would be involved. Using a stronger magnet would increase the size of the peak but not its width. Increasing the number of loops in the coil would also increase emf but also increases the resistance of the coil so may have little effect on the size of the current.

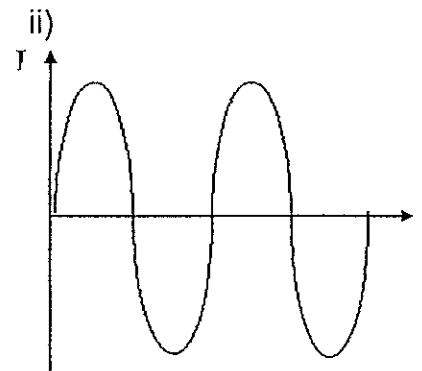
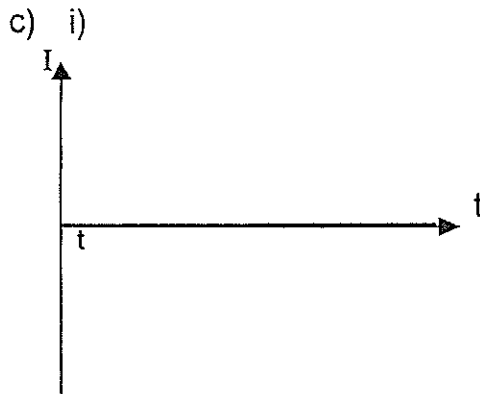

4. a) Equipment needed – a voltmeter connected to the coil.

b) Line of best fit drawn: Gradient $\frac{\Delta V}{\Delta N} = \frac{180 \times 10^{-3}}{70 - 5} = 2.77 \text{ mV}$

c) Faraday's Law: $\text{emf} = \frac{N \Delta \phi}{\Delta t}$

$$\Delta \phi = \Delta BA = \pi r^2 \times \Delta B = \pi \times (25 \times 10^{-3})^2 \times 0.42 = 8.2 \times 10^{-4} \text{ Wb}$$

$$\therefore \Delta t = \frac{\Delta \phi}{\text{gradient}} = \frac{8.2 \times 10^{-4}}{2.77 \times 10^{-3}} = 0.298 \text{ s}$$

5.

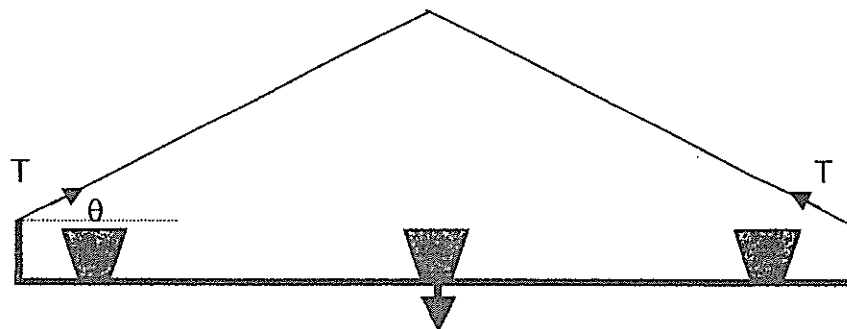

- a) Total mass = 11 kg

Forces: $2T \sin \theta = 11 \times 9.8$ $\cos \theta = 0.7/0.9 = 0.7777 \therefore \theta = 38.95^\circ$

$$T = \frac{107.8}{2 \times \sin 38.95^\circ} = 85.7 \text{ N}$$

b) $\sigma = 11 \times 10^8 \text{ Pa} = F/A$ $F = 85.7 \text{ N}$

$$A = 85.7 / 11 \times 10^8 = 7.79 \times 10^{-8} \text{ m}^2 = \pi r^2$$

$$r = \sqrt{7.79 \times 10^{-8} / \pi}$$

$$r = 1.57 \times 10^{-4} \text{ m or diameter} = \mathbf{0.314 \text{ mm}}$$

c) $\Delta L = FL / (AY) = \frac{85.7 \times 0.9}{\pi(0.25 \times 10^{-3})^2 \times 2.1 \times 10^{11}}$

$\Delta L = \mathbf{1.87 \text{ mm}}$ – not very much of a stretch.

d) Shortening the wires will make the angle to the horizontal smaller but the same weight is supported ($= 2T \sin \theta$) so T must become larger. A larger tension may cause them to break.

6. a) Acceleration is a maximum at $t = 0$ and decreases to zero after about 4 s.

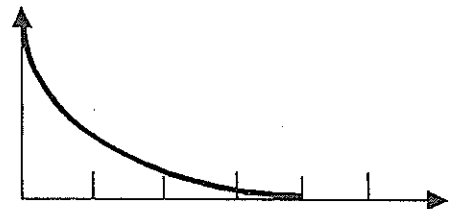

b) Acceleration = slope of the velocity/ time graph at $t = 1$
 slope $\approx 8/3 \approx \mathbf{3 \text{ ms}^{-2}}$

c) Distance travelled = **area under the curve** up to $t = 5 \text{ s}$.
 Adding up squares: $\mathbf{d \approx 45 \text{ m}}$

d) Estimate of velocity = 400 in 50 s gives $v = 8 \text{ ms}^{-1}$ and if mass = 65 kg

$$F = mv^2 / r \approx \frac{65 \times 64}{30} \approx \mathbf{140 \text{ N}}$$

7. a) $75 \text{ kmh}^{-1} = 75/3.6 = \mathbf{20.8 \text{ ms}^{-1}}$
 $V_H = 20.8 \times \cos 14 = \mathbf{20.2 \text{ ms}^{-1}}$
 $V_V = 20.8 \times \sin 14 = \mathbf{5.03 \text{ ms}^{-1}}$

b) At the highest point, horizontal component of velocity is still 20.2 ms^{-1} (as there is negligible force horizontally, the horizontal components of velocity will remain constant) and vertical component of velocity is zero (at the top of flight gravitational acceleration has reduced the vertical component velocity to zero).

- c) i) **Zero** (all forces balanced – the velocity of the car is constant)
 ii) **9.8 ms⁻¹ downwards** (car is now in free fall)

- d) Speed at B is **equal to** that at A
 Speed at C is **less than** that at A
 Speed at D is **greater than** that at A

- e) Horizontally: Time taken to travel 30 m is given by $t = 30 / V \cos 14$

$$\text{Vertically: } s = ut + \frac{1}{2} at^2 \quad \text{i.e. } 0 = \frac{V \sin 14 \times 30}{V \cos 14} - \frac{4.9 \times 30^2}{V^2 \cos^2 14}$$

$$V = 25.0 \text{ ms}^{-1} \text{ or } 90 \text{ kmh}^{-1}$$

SECTION C

- a) Motors act as generators when turned. The kinetic energy of the car is used to turn the motor and generate electrical energy. The car loses its kinetic energy and hence its speed. By braking in this way current is regenerated.
- b) Converting energy stored from the battery is 90% efficient, and the generating system has an efficiency of 33%.
 Total efficiency = $0.33 \times 0.90 = 0.297 = 29.7\%$ which is 4.7% more efficient than petrol engines (25%). The statement is reasonable.
- c) 50 Ultracapacitors can store an energy content of $50 \times 15 = 750$ watt-hours. Operating at a power of 75 kW the engine would be able to run for a time of $(t = E/P) 750 / 75000$ hours = 0.01 hours or about **30 seconds**.
- d) Assume coil size: 150 mm

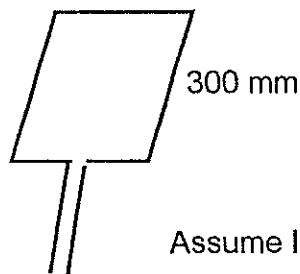

Assume $I = 30 \text{ A}$, $N = 4000$ turns

$$\tau = BIL \times 2r \times N = 0.1 \times 30 \times 0.3 \times 2 \times .075 \times 4000 \approx 500 \text{ N m}$$

- e) Energy is lost due to heating in wires, friction in wheels and bearings, and drag through the air ("wind resistance").

2. a) Stars are such a long way away that the wobble would be impossible to see with the eye and not measurable (1/7 of a millionth of a degree).
- b) 55 days
- c) No. There would be no component of motion along the line of sight. For Doppler shift to be seen the star must wobble toward and away from the earth.

d) $a = F/m = GM/r^2$

$$= \frac{6.67 \times 10^{-11} \times 1.99 \times 10^{30}}{(7.78 \times 10^{11})^2}$$

$$= 2.19 \times 10^{-4} \text{ ms}^{-2}$$

- e) The two bodies revolve around their combined centre of mass. The radius of each orbit is in inverse proportion to the mass of the body:

$$\frac{R_s}{R_E} = \frac{M_E}{M_s}$$

$$R_s = \frac{5.98 \times 10^{24} \times R_E}{1.99 \times 10^3} = 3.00 \times 10^6 R_E (4.5 \times 10^5 \text{ m})$$

The Science Teachers' Association of WA acknowledges the support of the Curriculum Council and in particular the Physics TEE Examining Panel members: Dr Ian Bailey, Dr Timothy St Pierre and Mr George Przywolnik

